

CS800 STEPPER

OWNER'S MANUAL

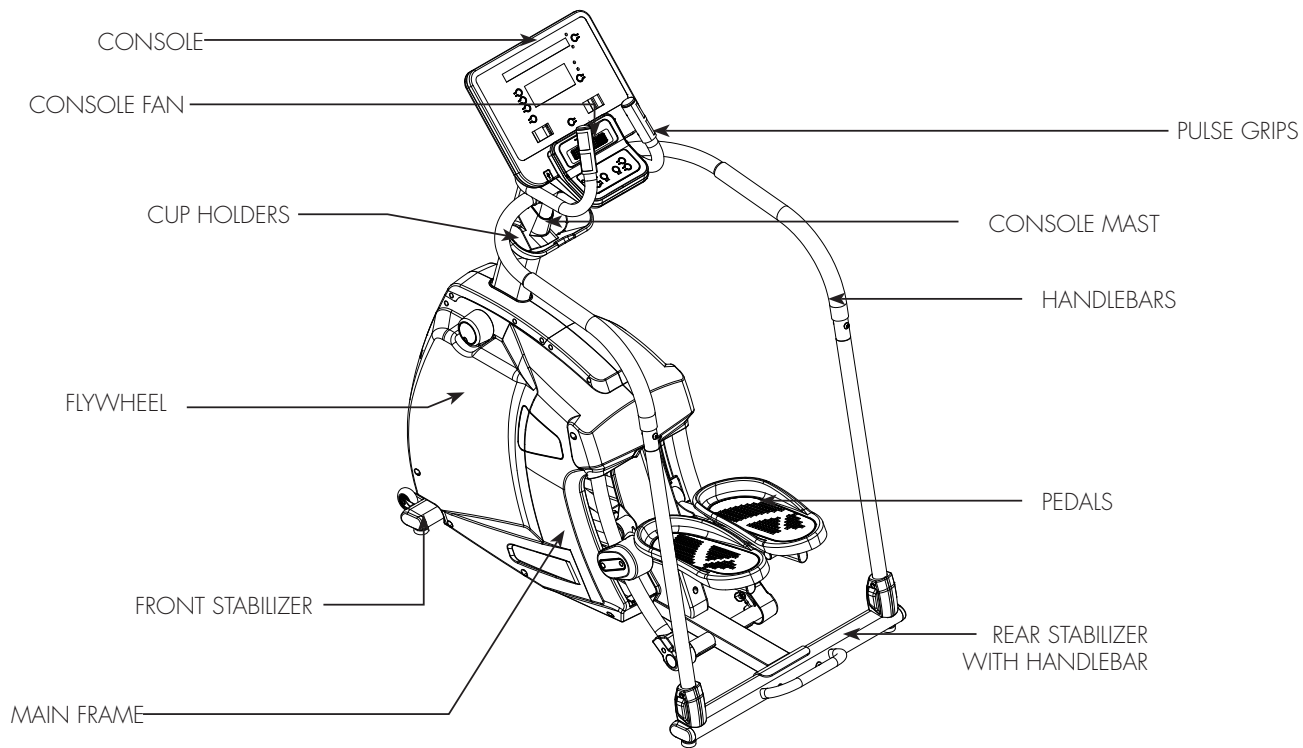

TABLE OF CONTENTS

3	PRODUCT REGISTRATION
4	IMPORTANT SAFETY INSTRUCTIONS
5	IMPORTANT ELECTRICAL INSTRUCTIONS
6	IMPORTANT OPERATION INSTRUCTIONS
8	CS800 ASSEMBLY INSTRUCTIONS
15	CONSOLE OPERATION
20	PROGRAMMABLE FEATURES
29	HEART RATE PROGRAM
34	GENERAL MAINTENANCE
37	MANUFACTURER'S LIMITED WARRANTY
40	EXPLODED VIEW
41	PARTS LIST

Thank you for purchasing our product, please save these instructions. Please do not perform or attempt any customizing, adjustments, repair or maintenance that is not described in this manual.



Congratulations on your new stepper and welcome to the Spirit Fitness family!

Thank you for your purchase of this quality stepper from Spirit Fitness. Your new stepper was manufactured by one of the leading fitness manufacturers in the world and is backed by one of the most comprehensive warranties available. Through your dealer, Spirit Fitness will do all we can to make your ownership experience as pleasant as possible for many years to come. If not purchased direct from Spirit Fitness, the local dealership where you purchased this stepper is your administrator for all Spirit Fitness warranty and service needs. Their responsibility is to provide you with the technical knowledge and service personnel to make your experience more informed and any difficulties easier to remedy.

Please take a moment at this time to record the name of the dealer, their telephone number, and the date of purchase below to make any future, needed contact easy. We appreciate your support and we will always remember that you are the reason that we are in business.

Yours in Health,
Spirit Fitness

NAME OF DEALER _____

DEALER PHONE # _____

PURCHASE DATE _____

RECORD YOUR SERIAL NUMBER

Please record the serial number of this fitness product in the space provided below.

Serial Number:

REGISTER YOUR PURCHASE

The self-addressed product registration card must be completed in full and returned to Spirit Fitness. You can also go to <https://www.spiritfitness.com/commercialwarrantyregistration.html> under the Support tab to register online.

IMPORTANT SAFETY INSTRUCTIONS

WARNING

When using an electrical appliance, basic precautions should always be followed, including the following: read all instructions before using this appliance.

DANGER – To reduce the risk of electric shock: always unplug this appliance from the electrical outlet immediately after using and before cleaning.

WARNING – To reduce the risk of burns, fire, electric shock, or injury to persons, install the stepper on a flat level surface with access to a 110-volt, 5-amp grounded outlet with only the stepper plugged into the circuit.

DO NOT USE AN EXTENSION CORD UNLESS IT IS A 14AWG OR BETTER, WITH ONLY ONE OUTLET ON THE END:

- Do not operate stepper on deeply padded, plush or shag carpet. Damage to both carpet and stepper may result.

- Keep children away from the stepper. There are obvious pinch points and other caution areas that can cause harm.
- Keep hands away from all moving parts.
- Never operate the stepper if it has a damaged cord or plug. If the stepper is not working properly, call your dealer.
- Keep the cord away from heated surfaces.
- Do not operate where aerosol spray products are being used or where oxygen is being administered. Sparks from the motor may ignite a highly gaseous environment.
- Never drop or insert any object into any openings.
- Do not use outdoors.
- To disconnect, turn all controls to the off position, then remove the plug from the outlet.
- Do not attempt to use your stepper for any purpose other than for the purpose it is intended.
- The hand pulse sensors are not medical devices. Their purpose is to provide you with an approximate measurement in relation to your target heart rate. Use of a chest transmitter strap (sold separately) is a much more accurate method of heart rate analysis. Various factors, including the user's movement, may affect the accuracy of heart rate readings. The pulse sensors

are intended only as exercise aids in determining heart rate trends in general.

- Wear proper shoes. High heels, dress shoes, sandals or bare feet are not suitable for use on your stepper. Quality athletic shoes are recommended to avoid leg fatigue.
- This appliance is not intended for use by persons with reduced physical, sensory or mental capabilities, or lack of experience and knowledge, unless they have been given supervision or instruction concerning use of the appliance by a person responsible for their safety.
- Keep children under the age of 13 away from this machine.

SAVE THESE INSTRUCTIONS - THINK SAFETY!

IMPORTANT ELECTRICAL INSTRUCTIONS

WARNING

NEVER remove any cover without first disconnecting AC power. If voltage varies by ten percent (10%) or more, the performance of your stepper may be affected. Such conditions are not covered under

your warranty. If you suspect the voltage is low, contact your local power company or a licensed electrician for proper testing. NEVER expose this stepper to rain or moisture. This product is NOT designed for use outdoors, near a pool or spa, or in any other high humidity environment. The operating temperature specification is 40 to 120 degrees Fahrenheit, and humidity is 95% non-condensing (no water drops forming on surfaces).

Circuit Breakers: some circuit breakers used in homes are not rated for high inrush currents that can occur when a stepper is first turned on or even during use. If your stepper is tripping the house circuit breaker (even though it is the proper current rating) but the circuit breaker on the stepper itself does not trip, you will need to replace the home breaker with a high inrush type. This is not a warranty defect. This is a condition we as a manufacture have no ability to control. This part is available through most electrical supply stores. Examples: Grainger part # 1D237, or available online at www.squared.com part #QO120HM. The electrical outlet used should have a dedicated 5-amp circuit breaker.

GROUNDING INSTRUCTIONS

This product must be grounded. If the stepper should malfunction or breakdown, grounding provides a path of least resistance for electric current, reducing the risk of electric shock. This product is equipped with a cord having an equipment-grounding plug. The plug must be plugged into an appropriate outlet that is properly installed and grounded in accordance with all local codes and ordinances.

DANGER - Improper connection of the equipment-grounding conductor can result in a risk of electric shock. Check with a qualified electrician or serviceman if you are in doubt as to whether the product is properly grounded. Do not modify the plug provided with the product if it will not fit the outlet; have a proper outlet installed by a qualified electrician.

This product is for use on a nominal 110-volt/5-amp dedicated circuit, and has a grounding plug that looks like the plug illustrated below. A temporary adapter that looks like the adapter illustrated below may be used to connect this plug to a 2-pole receptacle as shown below if a properly

grounded outlet is not available. The temporary adapter should be used only until a properly grounded outlet, (shown below) can be installed by a qualified electrician. The green colored rigid ear-lug, or the like, extending from the adapter, must be connected to a permanent ground such as a properly grounded outlet box cover. Whenever the adapter is used, it must be held in place by a metal screw.

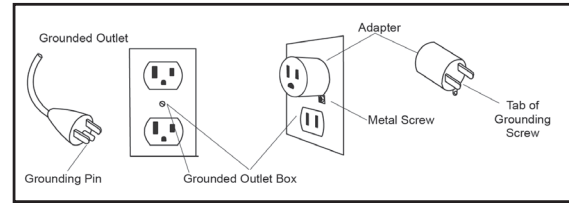

IMPORTANT OPERATION INSTRUCTIONS

- NEVER operate this stepper without reading and completely understanding the results of any operational change you request from the computer.
- Understand that changes in resistance do not occur immediately. Set your desired resistance level on the computer console and release the adjustment button. The computer will obey the command gradually.

- Use caution while participating in other activities while pedaling on your stepper; such as watching television, reading, etc. These distractions may cause you to lose balance which may result in serious injury.
- Do not use excessive pressure on console control buttons. They are precision set to function properly with little finger pressure.

WARNING

This product can expose you to chemicals including Toluene and Acrylamide which are known to the State of California to cause Cancer and birth defects or other reproductive harm. For more information, go to www.P65Warnings.ca.gov

CS800 PRE-ASSEMBLY

UNPACKING

1. Cut the straps, then lift the box over the unit and unpack.
2. Carefully remove all parts from the carton and inspect for any damage or missing parts. If parts are damaged or missing, contact your dealer immediately.
3. Locate the hardware package. Remove the tools first. Remove the hardware for each step as needed to avoid confusion. The numbers in the instructions that are in parenthesis (#) are the item number from the assembly drawing for reference.

TOOLS INCLUDED:

- 13/14m/m_Wrench (116)
- 12/14m/m_Wrench (117)
- Phillips Head Screw Driver (118)
- L Allen Wrench-M8 (119)
- L Allen Wrench-M6 (120)

PARTS INCLUDED:

- 1 Main Frame
- 1 Console Mast
- 2 Console Mast Cover (Left and Right)
- 4 Handlebar Tubing
- 4 Levelers
- 1 Rear Stabilizer
- 1 Console
- 2 Foot Pedals
- 1 Power Cord
- 2 Transport Wheels
- 1 Water Bottle Holder
- 1 Hardware Kit

CS800 STEP ZERO

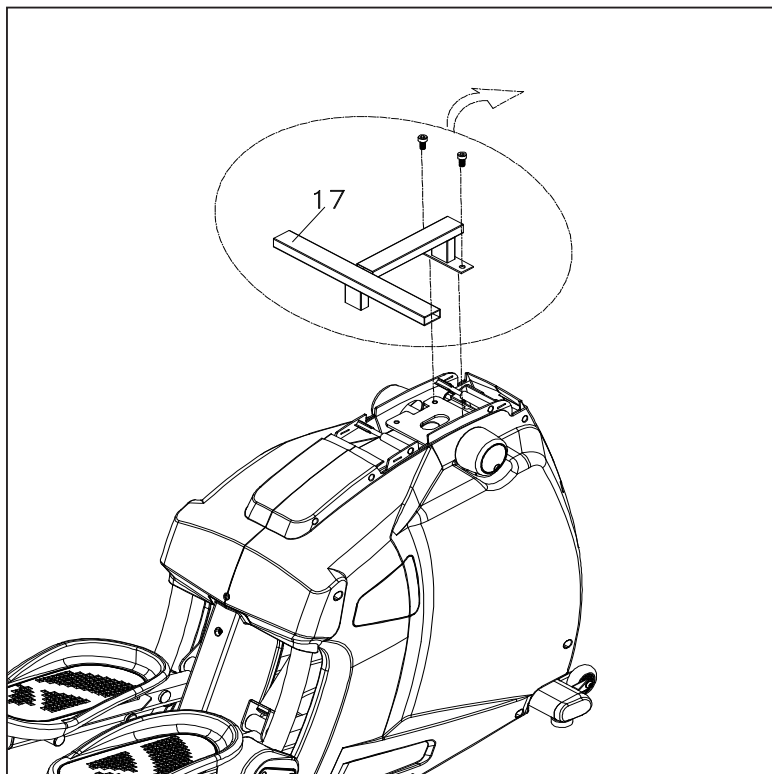

1. Use L Allen Wrench (No.119) to remove two $3/8"$ \times $3/4"$ Socket Head Cap Bolts that hold the protective Side Back (No.17) onto the mounting plate on the Main Frame. Discard the bolts and set the Side Back (No.17) aside.

CS800 STEP ONE

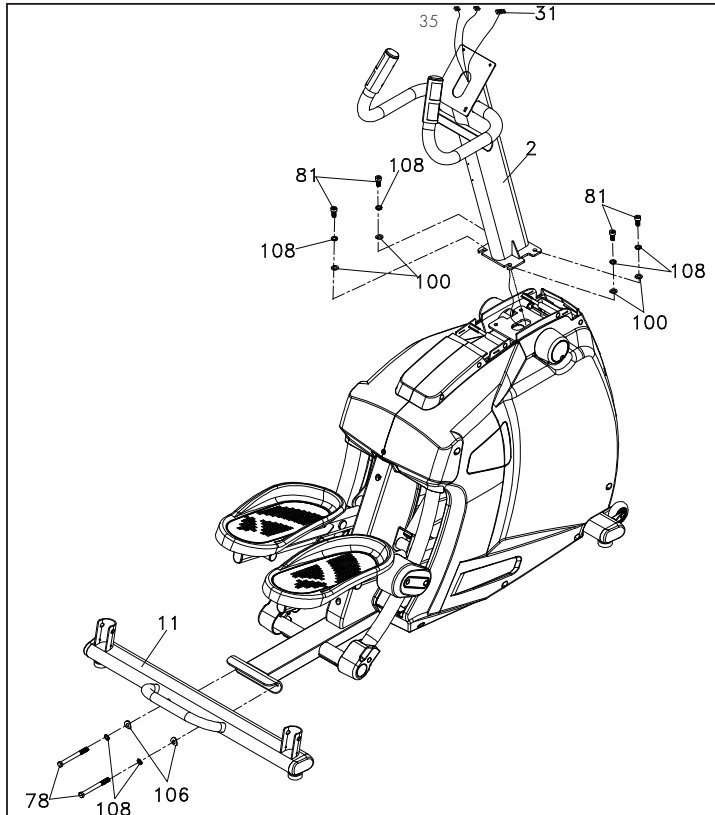

HARDWARE FOR STEP 1

PART	TYPE	DESCRIPTION	QTY
78	HEX HEAD BOLT	3/8" x 3-3/4"	2
81	SOCKET HEAD CAP BOLT	3/8" x 3/4"	4
100	FLAT WASHER	3/4" x ø19 x 1.5T	4
106	CURVED WASHER	3/8" x 23 x 2.0T	2
108	SPRING WASHER	ø10 x 2T"	6

1. Attach **Rear Stabilizer with Handle (No.11)** to mounting plate on the main frame and secure with two **Hex Head Bolts (No.78)**, two **Spring Washers (No.108)** and **Curved Washers (No.106)** by using **Wrench (No.116)**.
2. Pull the tie on the **Console Mast (No.2)** to have **Computer Cable (No.31)** and **Handpulse Cables (No.35)** go through the mast from bottom and out of the mast on top. Secure the **Console Mast (No.2)** on the mounting plate on the Main Frame with four **Socket Head Cap Bolts (No.81)**, four **Spring Washers (No.108)** and four **Flat Washers (No.100)** by using **L Allen Wrench (No.119)**.

CS800 STEP TWO

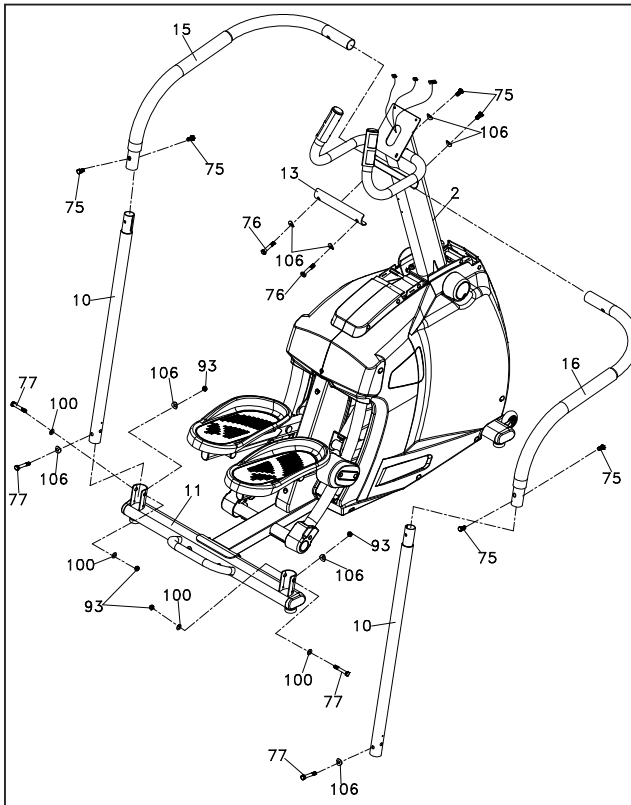

HARDWARE FOR STEP 2

PART	TYPE	DESCRIPTION	QTY
75	HEX HEAD BOLT	3/8" x 3/4"	6
76	BUTTON HEAD SOCKET BOLT	3/8" x 16 x 2"	2
77	HEX HEAD BOLT	3/8 x 2-14"	4
93	NYLOC NUT	3/8" x 7T	4
100	FLAT WASHER	3/8" x 19"1.5T	4
106	CURVED WASHER	3/8" x 23 x 2.0T	8

1. Place **Upper Left Handlebar (No.15)** (with orientation of 90-degree bend at front) onto **Connecting Plate** welded to the **Console Mast (No.2)** and secure it with a **Hex Head Bolt (No.75)** and a **Curved Washer (No.106)** to the **Connecting plate** (do not tighten completely). Then insert one of **Handlebar Connecting Tube (No.10)** to connect with **Upper Left Handlebar (No.15)** at the 107-degree-bending end and temporarily with two **Button Head Socket Bolts (No.75)** with **L Allen Wrench-M6 (No.120)**. Then attach the bottom end of **Handlebar Connecting Tube (No.10)** to the U-shape mounting at left side of **Rear Stabilizer with Handle (No.11)**. Use two **Hex Head Bolts (No.77)** together with two **Flat Washers (No.100)**, two **Curved Washers (No.106)** and two **Nyloc Nuts (No.93)** to tighten by using **Wrench (No.116)** and **Wrench (No.117)**. Tighten and secure all other bolts.

CS800 STEP TWO - Continued

2. Repeat process for **Upper Right Handlebar (No.16)** and the other **Handlebar Connecting Tube (No.10)**.
3. Attach **Handlebar Connecting Plate (No.13)** to **Upper Handlebars (No.15 & 16)**. Secure with two **Button Head Socket Bolts (No.76)** and two **Curved Washers (No.106)** by using **Wrench (No.116)**. Tighten all hardware listed in this step.

CS800 STEP THREE

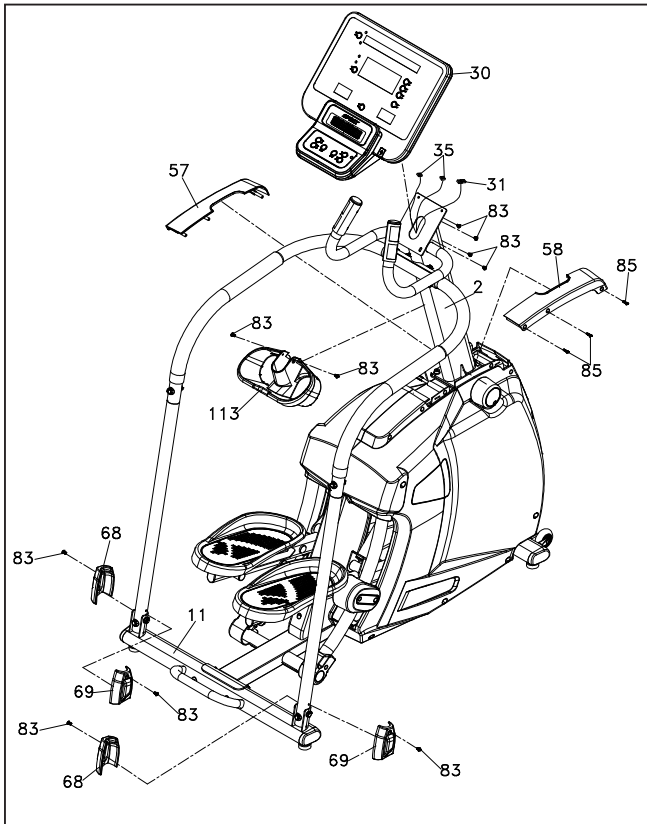

HARDWARE FOR STEP 3

PART	TYPE	DESCRIPTION	QTY
83	SCREW	M5 x 10MM	10
85	SHEET METAL SCREWS	4 x 15	3

1. Match **Left Console Mast Cover (No.57)** with **Right Console Mast Cover (No.58)** on top of left and right Chain Covers and around the **Console Mast (No.2)** and secure with three **Sheet Metal Screws (No.85)** by using the **Phillips Head Screw Driver (No.118)**.
2. Match **Left and Right Handlebar Caps (No.68, 69)** together on the U-shape mounting at left side of **Rear Stabilizer with Handle (No.11)** and use the **Phillips Head Screw Driver (No.118)** to tighten two **Phillips Head Screws (No.83)** and secure. Match **Left and Right Handlebar Caps (No.68, 69)** together on U-shape mounting at right side of **Rear Stabilizer with Handle (No.11)** and repeat the process above.
3. Take off the tie from the **Computer Cable (No.31)** and plug it into the **Console Assembly (No.30)** together with the two **Handpulse Assembly Cables (No.35)**. Place the **Console (No.30)** on the mounting plat of the **Console Mast (No.2)** and secure with four **Phillips Head Screws (No.83)** by using the **Phillips Head Screw Driver (No.118)**.

CS800 STEP THREE - Continued

4. Secure the **Water Bottle Holder (No.113)** on the **Console Mast (No.2)** with two **Phillips Head Screws (No.83)** by using the **Phillips Head Screw Driver (No.118)**.



CS800 CONSOLE OPERATION



POWER

When the AC power cord is connected to the Stepper, the console will automatically power up. When initially powered on the console will perform an internal self-test. During this time all the lights will turn on. When the lights go off, the **Dot Matrix Message Center** will show the software version (i.e.: VER 1.0). The **LED Data Display Window** shows the total hours of use and total steps. The odometer will remain displayed for only a few seconds then the console will go to the start up display. The **Dot Matrix Message Center** display will be scrolling through the different profiles of the programs and will be scrolling the start up message. You may now begin to use the console.

C-SAFE FEATURE

Your console is equipped with a C-SAFE feature. The Power (POWER) port can be used for powering a remote controlled audio-visual system by connecting a cable from the remote to the Power port at the back of the console. The Communication port (COMM) can be used to interact with fitness software applications.

QUICK START

This is the quickest way to start a workout. After the console powers up you just press the **Start** key to begin. This will initiate the **Quick Start** mode. In **Quick Start** the Time will count up from zero, all workout data will start to accrue and the workload may be adjusted manually by pressing the **Level Up** and **Down** buttons. The **Dot Matrix Message Center** will show just the bottom row lit. As you increase the workload more rows will light indicating a harder workout. The Stepper will get harder to pedal as the rows increase. The **Dot Matrix Message Center** has 24 columns of lights and each column represents 1 minute. At the end of the 24th column (or 24 minutes of work) the display will wrap around and start at the first column again.

There are 20 levels of resistance available for plenty of variety. The first 5 levels are very easy workloads and the changes between levels are set to a good progression for de-conditioned users. Levels 6-10 are more challenging, but the increases in resistance from one level to the next remain small. Levels 11-15 start

getting tough as the levels jump more dramatically. Levels 16-20 are extremely difficult and are good for short interval peaks and elite athletic training.

BASIC INFORMATION

The **Dot Matrix Message Center**, or **Profile Window**, will display the workout Profile. The **LED Data Display Window** displays pertinent exercise data. There is a **Strides Per Minute** window for pedal speed and a **Level** window indicating machine resistance.

The **LED Data Display Window** will initially be displaying **Steps**, **Calories**, **Pulse** and **Time Elapsed** information. When the **Up/Down Scan** key is pressed the next set of information will appear: **Vertical Distance**, **Watts**, **METs** and **Time Remaining**. Pressing the **Up/Down Scan** button, the Scan mode is activated and the **LED Data Display Window** will show each set of data for four seconds then switch to the next set of data in a continuous loop. Pressing the **Up/Down Scan** button again will bring you back to the beginning.

The **Stop** key button actually has several functions. Pressing the **Stop** key once during a program will pause the program for 5 minutes. If you need to get a drink, answer the phone, or any of the many things that could interrupt your workout, this is a great feature. To resume your workout during Pause just press the **Start** key. If the **Stop** key is pressed twice during a workout, the program will end and the console will return to the start-up screen. If the **Stop** key button is held down for 3 seconds, the console will perform a complete Reset. During data entry for a program the **Stop** key performs a Previous Screen function. This allows you to go back one step in the programming each time you press the **Stop** key button.

The **Program** Key is used to preview each program. When you first turn the console on, you may press program key to preview what the program profile looks like. If you decide that you want to try a program, press the **Enter** key to select the program and enter into the data setup mode.

1/4 MILE TRACK

The 1/4-mile track (0.4 km) will be displayed around the dot matrix window. The flashing dot indicates your progress. In the center of the track there is a lap counter for reference.

HEART RATE WINDOW

The Pulse (Heart Rate) window will display your current heart rate in beats per minute during the workout. You must use both left and right stainless steel sensors to pick up your pulse. Pulse values are displayed anytime the computer is receiving a Grip Pulse signal. You may use the Grip Pulse feature while in Heart Rate Control. The CS800 will also pick up wireless heart rate transmitters that are Polar compatible, including coded transmissions.

TO TURN STEPPER OFF

The display will automatically turn off (go to sleep) after 30 minutes of inactivity. This function is called sleep mode. In sleep mode, the stepper will power down most everything except for a minimum of circuitry for detecting button presses and the safety button so it will start up again if these are activated. There is only a tiny amount of current used in sleep mode (about the same as your TV when it is turned off) and it is perfectly fine to leave the main power switch on in sleep mode. Of course you may also remove the safety button or turn off the main power switch to power down the stepper.

PROGRAMMABLE FEATURES

Each of the programs can be customized with your personal information and changed to suit your needs. Some of the information asked for is necessary to ensure the readouts are correct. You will be asked for your Age and Weight. Your Age is also necessary during the Heart Rate control program to ensure the correct settings are in the program for your Age. Otherwise the work settings could be too high or low for you; entering your Weight aides in calculating a more correct Calorie reading. Although we cannot provide an exact calorie count we do want to be as close as possible.

CALORIE NOTE: Calorie readings on every piece of exercise equipment, whether it is in a gym or at home, are not accurate and tend to vary widely. They are meant only as a guide to monitor your progress from workout to workout. The only way to measure your calorie burn accurately is in a clinical setting connected to a host of machines. This is because every person is different and burns calories at a different rate. Some good news is that you will continue to burn calories at an accelerated rate for at least an hour after you have finished exercising!

ENTERING A PROGRAM & CHANGING SETTINGS

When you enter a program (by pressing the Program button to choose a program, then the Enter key to select it) you have the option of entering your own personal settings. If you want to work out without entering new settings then just press the **Start** button. This will bypass the programming of data and take you directly to the start of your workout. If you want to change the personal settings then just follow the instructions in the **Dot Matrix Message Center**. If you start a program without changing the settings the default – or pre-saved – settings will be used.

MANUAL

The **Manual** program works as the name implies, manually. This means that you control the workload yourself and not the computer. To start the **Manual** program follow the instructions below.

1. Using the **Program** button select **Manual** then press the **Enter** button.
2. The **Dot Matrix Message Center** will ask you to enter your **Age**. You may enter your Age, using the **Up** and **Down** buttons or the numeric button pad, then press the **Enter** button to accept the new number and proceed on to the next screen.
3. You are now asked to enter your **Weight**. You may adjust the Weight number using the **Up** and **Down** buttons, or the numeric button pad, then press **Enter** to continue.
4. The next setting is **Time**. You may adjust the Time and press **Enter** to continue.
5. Now you are finished editing the settings and can begin your workout by pressing the **Start** button. You can also go back and modify your settings by pressing the **Enter** button.
*NOTE: At any time during the editing of data you can press the **Stop** button to go back one level, or screen.*
6. The program automatically starts you at level one. This is the easiest level and it is a good idea to stay at level one for a while to warm up. If you want to increase the work load at any time press the **Up** button; the **Down** button will decrease the workload.
7. During the Manual program you will be able to scroll through the data in the **LED Data Display Window** by pressing the adjacent **Up/Down Scan** button. You may also switch between the profile display and a quarter mile track by pressing the **Up/Down Scan** button adjacent to the **LED Data Display Window**.
8. When the program ends you may press **Start** to begin the same program again or **Stop** to exit the program, or you can save the program you just completed as a custom program by pressing the **Program** button and selecting **Custom**, then following the instructions in the **Dot Matrix Message Center**.

PRESET PROGRAMS

The stepper has ten different programs that have been designed for a variety of workouts. These ten programs have factory preset work level profiles for achieving different goals.

HILL

This program follows a triangle or pyramid type of gradual progression from approximately 10% of maximum effort (the level that you chose before starting this program) up to a maximum effort which lasts for 10% of the total workout time, then a gradual regression of resistance back to approximately 10% of maximum effort.

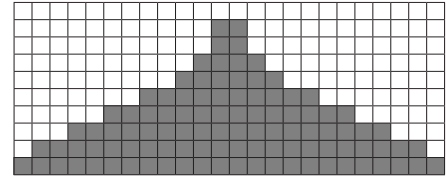

FAT BURN

This program follows a quick progression up to the maximum resistance level (default or user input level) that is sustained for 2/3 of the workout. This program will challenge your ability to sustain your energy output for an extended period of time.

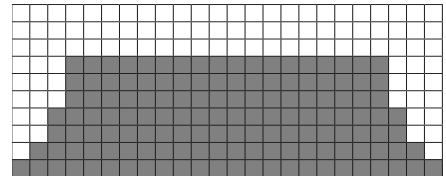

CARDIO

This program presents a quick progression up to near maximum resistance level (default or user input level). It has slight fluctuations up and down to allow your heart rate to elevate, and then recover repeatedly, before beginning a quick cool down. This will build up your heart muscle and increase blood flow and lung capacity.

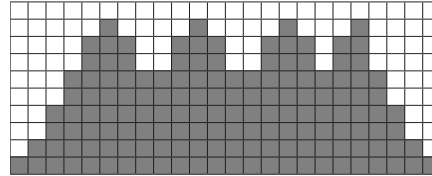

INTERVAL

This program takes you through high levels of intensity followed by recovery periods of low intensity. This program utilizes and develops your “Fast Twitch” muscle fibers which are used when performing tasks that are intense and short in duration. These deplete your oxygen level and spike your heart rate, followed by periods of recovery and heart rate drop to replenish oxygen. Your cardiovascular system gets programmed to use oxygen more efficiently.

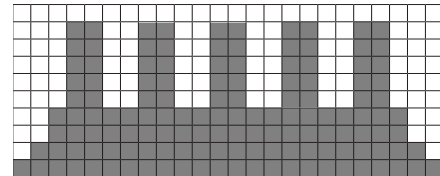

HIIT PROGRAM

The HIIT, or High Intensity Interval Training, program takes advantage of the latest trend in fitness. During the program you will perform short bursts of high intensity sprinting followed by short rest periods. HIIT is a fully customizable interval training program. You can enter the number of intervals, time of each interval Sprint and Rest periods and the work intensity of the levels.

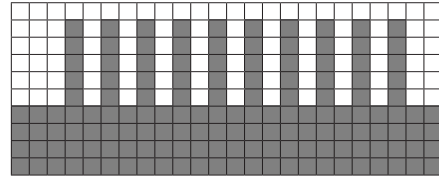

PROGRAMMING PRESET PROGRAMS

1. Using the **Program** button select your desired program then press the **Enter** button.
2. The **Dot Matrix Message Center** will ask you to enter your **Age**. You may adjust the age setting, using the **Up** and **Down** buttons, then press the **Enter** button to accept the new number and proceed on to the next screen.
3. You are now asked to enter your **Weight**. You may adjust the weight number using the **Up** and **Down** buttons, then press **Enter** to continue.
4. Next is **Time**. You may adjust the **Time** and press **Enter** to continue.
5. Now you are asked to adjust the **Max Level**. This is the peak exertion level you will experience during the program (at the top of the hill). Adjust the level and then press **Enter**.
6. Now you are finished editing the settings and can begin your workout by pressing the **Start** button. You can also go back and modify your settings by pressing the **Stop** button to go back one level, or screen.
7. If you want to increase or decrease the workload at any time during the program press the **Up** or **Down** button. This will change the workload settings of the entire profile, although the profile picture on the screen will not change. The reason for this is so that you can see the entire profile at all times. If the profile picture is changed it will look distorted and not a true representation of the actual profile. When you make a change to the workload, the **Dot Matrix Message Center** will show the current column, and program maximum, levels of work.
8. During the program you will be able to scroll through the data in the **LED Data Display Window** by pressing the **Up/Down** button next to the **LED Data Display Window**.
9. When the program ends the **LED Data Display Window** will show a summary of your workout. The summary will be displayed for a short time then the console will return to the start-up display.

CUSTOM USER-DEFINED PROGRAMS

The **Custom** Program allows you to build and save a custom program. You can build your own custom program by following the instructions below or you can save any other preset program you complete as a custom program. The **Custom** Program allows you to further personalize it by adding your facility name.

1. Press the **Custom** button. The **Dot Matrix Message Center** will show a welcome message; if you had previously saved a program the message will contain the name you gave it. Then press the **Enter** button to begin programming.
2. When you press **Enter**, the **Dot Matrix Message Center** will show "Name – A", if there is no name saved. If the name "Custom Workout" had been previously saved the **Message Window** will show "Name – Custom Workout" and the C in Custom will be blinking. If there is a name saved you can change it or you may press the Stop button to keep the name and continue to the next step. If you want to enter a name use the **Up** and/or the **Down** button to change the first letter then press **Enter** to save the first letter and continue to the next letter. When you have finished entering the name press the **Stop** button to save the name and continue to the next step.
3. The **Dot Matrix Message Center** will ask you to enter your **Age**. You may enter your **Age**, using the **Up** and **Down** buttons then press the **Enter** button to accept the new number and proceed on to the next screen.
4. You are now asked to enter your **Weight**. You may adjust the **Weight** number using the **Up** and **Down** buttons then press enter to continue.
5. Next is **Time**. You may adjust the **Time** and press **Enter** to continue.
6. Now you are asked to adjust the **Max Level**. This is the peak exertion level you will experience during the program. Adjust the level and then press **Enter**.
7. Now the first column will be blinking and you are asked to adjust the level for the first segment of the workout. When you finish adjusting the first segment, or if you don't want to change, then press **Enter** to continue to the next segment.
8. The next segment will show the same level as the previously adjusted segment. Repeat the same process as the last segment then press **Enter**. Continue this process until all twenty segments have been set.

9. The **Dot Matrix Message Center** will then tell you to press **Enter** to save the program. After saving the program the **Dot Matrix Message Center** says “New program saved” then will give you the option to start or modify the program. Pressing **Stop** will exit to the start up screen.
10. If you want to increase or decrease the workload at any time during the program press the **Up** or **Down** button. This will only affect the workload for the present position in the profile. When the profile changes to the next column it will return to the preset work level.
11. During the User 1 or User 2 program you will be able to scroll through the data in the **Dot Matrix Message Center** by pressing the adjacent **Up/Down** buttons, switch between the profile display and a quarter mile track by pressing the **Up/Down** buttons adjacent to the matrix, use the heart rate monitoring features and can switch to heart rate Auto-Pilot mode. See Heart Rate section for details of this feature).

HIIT PROGRAM

1. Using the **Program** button choose the **HIIT** program then press **Enter**.
2. The **Dot Matrix Message Center** will ask you to enter your **Age**. You may enter your **Age**, using the **Up** and **Down** keys, then press the **Enter** key to accept the new number and proceed on to the next screen.
3. You are now asked to enter your **Weight**. You may adjust the **Weight** number using the **Up** and **Down** keys then press **enter** to continue.
4. Next you are asked for the number of **Intervals** you want to do. The default is 10 and the range available is 3 to 15. One interval equals 1 Sprint and 1 Rest segment.
5. Now you are asked to adjust the **Sprint** level. This is the resistance level you will experience during the **Sprint** segments of the program. Adjust the level and then press **Enter**.
6. Now you are asked to adjust the **Rest** level. This is the resistance level you will experience during the Rest segments of the program. Adjust the level and then press **Enter**.
7. Next is entering the **Interval** time. The **LED Data Display Window** shows: Sprint Time:30 and Rest Time:30. The Sprint Time will be blinking. You may use the **Up** and **Down** keys to adjust the Sprint time from 20 to 60 seconds

then press **Enter**. The time for the Rest period will blink and you can adjust the time using the up and down keys and press **Enter**.

8. The **LED Data Display Window** will now display the total time for the HIIT workout; now press **Start** to begin. There is a 3-minute warm-up period before the first **Sprint** begins. The resistance level during warm-up is set to 5 but can be adjusted manually.
9. The **Dot Matrix Message Center** in the HIIT program is a speed indication display, not a power or resistance display. During the **Sprint** the **Dot Matrix Message Center** will show a blinking LED at the first **Sprint** segment. That is the target speed LED and indicates 90 pedal rpm. As you pedal faster the lights below the target speed LED light up the faster you go. When you exceed 90 rpm the target LED will move up showing you are past the target speed. You should maintain at least 90 rpm throughout the **Sprint** segments. The rest segments of the HIIT program are set to resistance level 5 and you can pedal at any speed you choose as your heart rate recovers. You can manually adjust the resistance levels during the **Sprint** and **Rest** segments.
10. At the end of the last **Sprint** there is a 2-minute cool-down period. You can bypass this by pressing the **Stop** key and the workout summary will be displayed.

HEART RATE PROGRAMS

The old motto, “no pain, no gain”, is a myth that has been overpowered by the benefits of exercising comfortably. A great deal of this success has been promoted by the use of heart rate monitors. With the proper use of a heart rate monitor, many people find that their usual choice of exercise intensity was either too high or too low and exercise is much more enjoyable by maintaining their heart rate in the desired benefit range.

To determine the benefit range in which you wish to train, you must first determine your Maximum Heart Rate. This can be accomplished by using the following formula: 220 minus your age. This will give you the Maximum Heart Rate (MHR) for someone of your age. To determine the effective heart rate range for specific goals you simply calculate a percentage of your MHR. Your heart rate training zone is 50% to 90% of your maximum heart rate. 60% of your MHR is the recommended for burning fat while 85% is recommended for strengthening the cardio vascular system. This 60% to 85% is the zone to stay in for maximum benefit.

For someone who is 40 years old their target heart rate zone is calculated:

$$220 - 40 = 180 \text{ (maximum heart rate)}$$

$$180 \times .6 = 108 \text{ beats per minute (60\% of maximum)}$$

$$180 \times .85 = 153 \text{ beats per minute (85\% of maximum)}$$

So for a 40 year old the training zone would be 108 to 153 beats per minute.

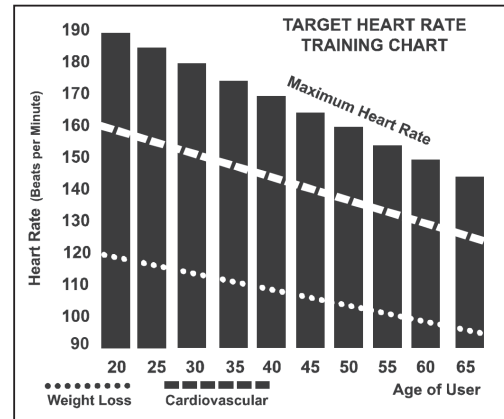

If you enter your age during programming the console will perform this calculation automatically. Entering your age is used for the Heart Rate programs. After calculating your MHR you can decide upon which goal you would like to pursue.

The two most popular reasons for, or goals, of exercise are cardiovascular fitness (training for the heart and lungs) and weight control. The black columns on the chart represent the MHR for a person whose age is listed at the bottom of each column. The training heart rate, for either cardiovascular fitness or weight loss, is represented by two different lines that cut diagonally through the chart. A definition of the lines' goal is in the bottom left-hand corner of the chart. If your goal is cardiovascular fitness or if it is weight loss, it can be achieved by training at 85% or 60%, respectively, of your MHR on a schedule approved by your physician. Consult your physician before participating in any exercise program.

With all Spirit Fitness machines you may use the heart rate monitor feature without using the Heart Rate program. However, when using the heart rate monitor feature in conjunction with the Heart Rate programs, the machine will automatically adjust speed or incline to maintain the desired heart rate.

HEART RATE PROGRAM OPERATION

To start the HR program follow the instructions below.

1. Using the **Program** button choose the **HR** program (65% or 80%) then press the **Enter** key.
2. The **Dot Matrix Message Center** will ask you to enter your **Age**. You may enter your **Age**, using the **Up/Down** keys, then press the **Enter** key to accept the new number and proceed on to the next screen.
3. You are now asked to enter your **Weight**. You may adjust the **Weight** number using the **Up/Down** keys, then press **Enter** to continue.
4. Next is **Time**. You may adjust the **Time** and press **Enter** to continue.
5. Now you are asked to adjust your target **Heart Rate**. This is the heart rate level you will try to maintain during the program. Adjust the value and then press **Enter**.
6. Now you are finished editing the settings and can begin your workout by pressing the **Start** key. You can also go back and modify your settings by pressing the **Enter** key. Note: At any time during the editing of data you can press the **Stop** key to go back one level, or screen.
7. If you want to increase or decrease the resistance at any time during the program, press the **Level Up/Down** key. This will allow you to change your target heart rate at any time during the program.
8. The program will automatically increase or decrease the amount of resistance, depending on whether your heart rate is above or below your target.

RATE OF PERCEIVED EXERTION

There are more variables involved in how hard you should workout than just heart rate. Your stress level, physical health, emotional health, temperature, humidity, the time of day, the last time you ate and what you ate, all contribute to the intensity at which you should workout.

The rate of perceived exertion (RPE), also know as the Borg scale, was developed by Swedish physiologist G.A.V. Borg. The scale helps users determine an approximate heart rate level when a heart rate monitor was not in use. Using the scale below, rate the level of intensity of your workout, or the perception of your effort during your workout. Once the rating has been determined, simply add a "0" to the rating to get your approximate heart rate. For example, if your workout felt comfortable, you would rate it a "12". Then add a "0" to get an approximate heart rate during your workout of 120 beats per minute. The scale is as follows:

Rating Perception of Effort:

6 Minimal	10 Very light +	14 Somewhat hard +	18 Very hard +
7 Very, very light	11 Fairly light	15 Hard	19 Very, very hard
8 Very, very light +	12 Comfortable	16 Hard +	20 Maximal
9 Very light	13 Somewhat hard	17 Very hard	

WEARING THE CHEST STRAP (SOLD SEPARATELY)

1. Attach the transmitter to the elastic strap using the interlocking button.
2. Adjust the strap as tightly as possible while ensuring it is still comfortable.
3. Position the transmitter with the logo centered in the middle of your torso facing away from your chest (some people must position the transmitter slightly left of center). Attach the final end of the elastic strap by inserting the round end and, using the locking parts, secure the transmitter and strap around your chest.
4. Position the transmitter directly below the pectoral muscles.
5. Sweat is the best conductor to measure very minute heart beat electrical signals. However, plain water can also be used to pre-wet the electrodes (2 ribbed oval areas on the reverse side of the belt and both sides of the transmitter). It's also recommended that you wear the transmitter strap a few minutes before your work out. Some users, because of body chemistry, have a more difficult time in achieving a strong, steady signal at the beginning. After "warming up", this problem lessens.
6. Your workout must be within range - distance between transmitter/receiver – to achieve a strong steady signal. The length of range may vary somewhat but generally stay close enough to the console to maintain good, strong, reliable readings. Wearing the transmitter directly on bare skin assures you of proper operation. If you wish, you may wear the transmitter over a shirt. To do so, wet the areas of the shirt that the electrodes will rest upon.

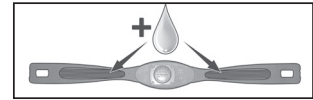
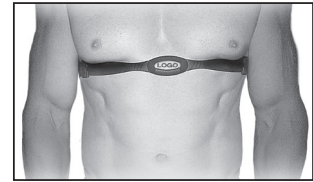

Note: The transmitter is automatically activated when it detects activity from the user's heart. Additionally, it automatically deactivates when it does not receive any activity. Although the transmitter is water resistant, moisture can have the effect of creating false signals, so you should take precautions to completely dry the transmitter after use to prolong battery life (estimated transmitter battery life is 2500 hours). The replacement battery is CR2032. The chest strap is sold separately. Chest straps that operate using Bluetooth or ANT+ should also work with this machine.

ERRATIC OPERATION

Caution! Do not use this stepper for Heart Rate programs unless a steady, solid Actual Heart Rate value is being displayed. High, wild, random numbers being displayed indicate a problem. Areas to look for interference which may cause erratic heart rate:

1. Microwave ovens, TV's, small appliances, etc.
2. Fluorescent lights.
3. Some household security systems.
4. Electric fence for a pet.
5. Some people have problems with the transmitter picking up a signal from their skin. If you have problems try wearing the transmitter upside down. Normally the transmitter will be oriented so the Spirit Fitness logo is right side up.
6. The antenna that picks up your heart rate is very sensitive. If there is an outside noise source, turning the whole machine 90 degrees may de-tune the interference.
7. Another Individual wearing a transmitter within 3' of your machine's console.

If you continue to experience problems contact your dealer.

GENERAL MAINTENANCE

Wipe down all areas in the sweat path with a damp cloth after each workout. If a squeak, thump, clicking or rough feeling develops the main cause is most likely one of two reasons:

1. The hardware was not sufficiently tightened during assembly. All bolts that were installed during assembly need to be tightened as much as possible. It may be necessary to use a larger wrench than the one provided if you cannot tighten the bolts sufficiently. It is important to note that 90% of calls to the service department for noise issues can be traced to loose hardware.
2. The crank arm nut needs to be retightened. If squeaks or other noises persist, check that the unit is properly leveled. There are 2 leveling pads on the bottom of the rear stabilizer, use a 14mm wrench (or adjustable wrench) to adjust the levelers.

ENGINEERING MODE

To enter the Maintenance Mode, pedal the stepper and press and hold down the Start, Stop and Enter keys. Keep holding the keys down for about 5 seconds and the Message Center will display Maintenance Mode. Press the Enter key to access the menu below:

1. Key Test (Will allow you to test all the keys to make sure they are functioning)
2. Display Test (Tests all the display functions)
3. Function
 - Units - Sets the display to read out in Imperial (miles, pounds, feet, etc.) or Metric (kilometers, kilograms, meters, etc.) display measurements
 - Pause mode (have five minutes)
 - Odometer Reset (Resets the odometer)
 - Sleep mode
 - Beep sound (Control Beep)
 - CAB Protocol or CSAFE Protocol
4. Service
 - Motor test
 - Csafe test
 - Sensor test (Test the speed sensor function)
5. Exit

STEPPER WARRANTY EFFECTIVE APRIL 1, 2020

Spirit Fitness warrants all its stepper parts for a period of time listed below from the date of retail sale, as determined by sale receipt, or in the absence of a sales receipt eighteen (18) months from the original factory shipping date. Spirit Fitness' responsibilities include providing new or remanufactured parts, at Spirit Fitness' option, and technical support to our independent dealers and servicing organizations. In the absence of a dealer or service organization, these warranties will be administered by Spirit Fitness directly to a facility. The warranty period applies to the following components:

WARRANTY	FRAME	PARTS	BRAKE	LABOR
Commercial (Non-Dues Paying Facilities)	Lifetime	5 Years	5 Years	2 Years
Residential	Lifetime	10 Years	10 Years	2 Years

NORMAL RESPONSIBILITIES OF THE CONSUMER

The non-dues paying facility is responsible for the items listed below:

1. The warranty registration card must be completed and returned to the address listed on the card within 10 days of the original purchase, or completed online to validate the manufacturer's limited warranty.
2. Proper use of the fitness equipment in accordance with the instructions provided in this manual
3. Proper installation in accordance with instructions provided with the fitness equipment and with all local electric codes.
4. Proper connection to a grounded power supply of sufficient voltage, replacement of blown fuses, repair of loose connections or defects in house or facility wiring.
5. Expenses for making the fitness equipment accessible for servicing, including any item that was not part of the fitness equipment at the time it was shipped from the factory.
6. Damages to the fitness equipment finish during shipping, installation or following installation.
7. Routine maintenance of this unit as specified in this manual.

EXCLUSIONS

This warranty does not cover the following:

1. CONSEQUENTIAL, COLLATERAL, OR INCIDENTAL DAMAGES SUCH AS PROPERTY DAMAGE AND INCIDENTAL EXPENSES RESULTING FROM ANY BREACH OF THIS WRITTEN OR ANY IMPLIED WARRANTY.
NOTE: Some states do not allow the exclusion or limitation of incidental or consequential damages, so this limitation or exclusion may not apply to you.
2. Service call reimbursement to the consumer. Service call reimbursement to the dealer that does not involve malfunction or defects in workmanship or material, for units that are beyond the warranty period, for units that are beyond the service call reimbursement period, for stepper not requiring component replacement, or stepper not in ordinary household or light commercial use.
3. Damages caused by services performed by persons other than authorized Spirit Fitness service companies; use of parts other than original Spirit Fitness parts; or external causes such as corrosion, discoloration of paint or plastic, alterations, modifications, abuse, misuse, accident, improper maintenance, inadequate power supply, or acts of God.
4. Products with original serial numbers that have been removed or altered.
5. Products that have been: sold, transferred, bartered, or given to a third party.
6. Products that do not have a warranty registration card on file at Spirit Fitness. Spirit Fitness reserves the right to request proof of purchase if no warranty record exists for the product.
7. THIS WARRANTY IS EXPRESSLY IN LIEU OF ALL OTHER WARRANTIES EXPRESSED OR IMPLIED, INCLUDING THE WARRANTIES OF MERCHANTABILITY AND/OR FITNESS FOR A PARTICULAR PURPOSE.
8. Product use in any environment other than a residential setting or non-dues paying facility with 5 hours use or less per day.
9. Warranties outside of the United States may vary. Please contact your local dealer for details.

SERVICE

Keep your bill of sale. Twelve (12) months from the date on the bill of sale or eighteen (18) months from the date of factory shipping as determined by the serial number establishes the labor warranty period should service be required. If service is performed, it is in your best interest to obtain and keep all receipts. This written warranty gives you specific legal rights. You may also have other rights that vary from state to state. Service under this warranty must be obtained by following these steps, in order:

1. Contact your selling authorized Spirit Fitness dealer. OR
2. Contact your local authorized Spirit Fitness service organization.
3. If there is a question as to where to obtain service, contact our service department at (870) 935-1107.
4. Spirit Fitness' obligation under this warranty is limited to repairing or replacing, at Spirit Fitness' option, the product through one of our authorized service centers. All repairs must be preauthorized by Spirit Fitness. If the product is shipped to a service center freight charges to and from the service center will be the customer's responsibility. For replacement parts shipped while the product is under warranty, the customer will be responsible for shipping and handling charges. For in-home service, the customer will be responsible for a trip charge. There will be an additional trip charge if the customer is located over 100 miles from the nearest service center.
5. The owner is responsible for adequate packaging upon return to Spirit Fitness. Spirit Fitness is not responsible for damages in shipping. Make all freight damage claims with the appropriate freight carrier. **DO NOT SHIP ANY UNIT TO OUR FACTORY WITHOUT A RETURN AUTHORIZATION NUMBER.** All units arriving without a return authorization number will be refused.
6. For any further information, or to contact our service department by mail, send your correspondence to:

SPIRIT FITNESS, INC.
P.O. Box 2037
Jonesboro, AR 72402-2037

Product features or specifications as described or illustrated are subject to change without notice. All warranties are made by Spirit Manufacturing, Inc. This warranty applies only in the 48 contiguous United States. NOTE: This does not apply to Alaska or Hawaii.

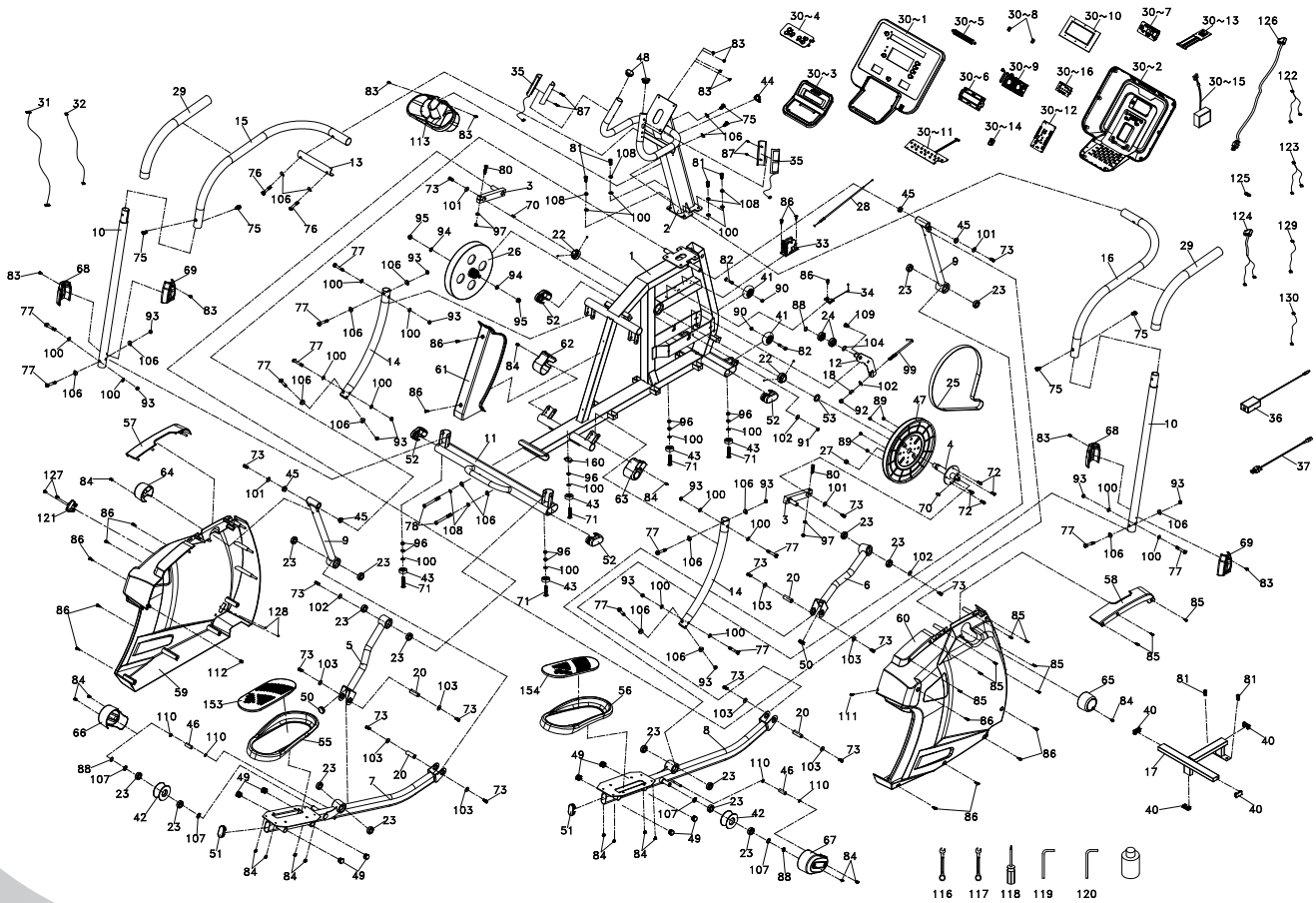

CS800XS200B-SS005-01 Part List_SPIRIT(SAP)		
1	Main Frame	1
2	Console Mast	1
3	Crank Arm	2
4	Crank Axle	1
5	Linked Assembly(L)	1
6	Linked Assembly(R)	1
7	Connecting Arm (L)	1
8	Connecting Arm (R)	1
9	Swing Assembly	2
10	Handgrip Connecting Tube	2
11	Rear Stabilizer with handle	1
12	Idler Wheel Assembly	1
13	Handgrip Connecting Plate	1
14	Curved Rail Tube	2
15	Left Handgrip(Upper)	1
16	Right Handgrip(Upper)	1
17	Side Back	1
18	Rod End Sleeve	1
20	Rod End Shaft	4
22	6005-2RS/B10+2M5 Bearing	2
23	6003 Bearing	16
24	6203 Bearing	2
25	Drive Belt	1
26	Flywheel	1
27	Magnet	1
28	Steel Cable	1
29	Handgrip Foam	2
30	Console Assembly	1
30~1	Console Top Cover	1
30~2	Console Bottom Cover	1
30~3	Console Inner Cover	1
30~4	Console Key Board	1
30~5	Deflector Fan Grill	1
30~6	Wind Duct	1
30~7	End Cap	1
30~8	Fan Grill Anchor	2
30~9	500m/m Fan Assembly	1

30~10	Console Display Board	1
30~11	Main Key Board	1
30~12	Interface Board	1
30~13	Bluetooth	1
30~14	USB charging module	1
30~15	VV/Receiver, HR	1
30~16	CASFE Board	1
31	1200m/m Computer Cable	1
32	100m/m Power Cord	1
33	Gear Motor	1
34	200m/m Reed Switch	1
35	850m/m Handpulse Assembly	2
36	Power Adaptor	1
37	Transformer Power Cord(Optional)	1
40	20 x 40L Square End Cap	4
41	Ø65 Transportation Wheel	2
42	Ø72 Slide Wheel , Urethane	2
43	Ø35 x 10 Rubber Foot	5
44	Bolt Access Cap	1
45	WFM-1719-12 Bushing	4
46	Ø15 x Ø8.6 x 38.5L Sleeve	2
47	Ø330 Drive Pulley	1
48	Ø32(1.8T) Button Head Plug	2
49	Ø25.4 x 2T Round Cap	8
50	Ø32 x 1.8T Round Cap	2
51	Ø30 x 60 Oval End Cap	2
52	Ø40 x Ø80 Oval End Cap	4
53	Spacer Bushing	1
55	Pedal (L)	1
56	Pedal (R)	1
57	Console Mast Cover (L)	1
58	Console Mast Cover (R)	1
59	Chain Cover (L)	1
60	Chain Cover (R)	1
61	Rear Shroud	1
62	Stabilizer Cover (L)	1
63	Stabilizer Cover (R)	1
64	Handle Bar Cover (L)	1
65	Handle Bar Cover (R)	1

66	Slide Wheel Cover (L)	1
67	Slide Wheel Cover (R)	1
68	Left Handgrip Cap	2
69	Right Handgrip Cap	2
70	Woodruff Key	2
71	3/8" x 2" Flat Head Socket Bolt	5
72	1/4" x UNC20 x 3/4" Hex Head Bolt	4
73	5/16" x UNC18 x 3/4" Hex Head Bolt	14
75	3/8" x 3/4" Button Head Socket Bolt	6
76	3/8" x UNC16 x 2" Button Head Socket Bolt	2
77	3/8" x 2-1/4" Hex Head Bolt	12
78	3/8" x 3-3/4" Hex Head Bolt	2
80	M8 x 35m/m Socket Head Cap Bolt	2
81	3/8" x 3/4" Socket Head Cap Bolt	6
82	5/16" x UNC18 x 1-3/4" Button Head Socket Bolt	2
83	M5 x 10m/m Phillips Head Screw	10
84	M5 x 10m/m Phillips Head Screw	16
85	Ø4 x 1.5L Sheet Metal Screw	10
86	5 x 19m/m Tapping Screw	15
87	3 x 20m/m Tapping Screw	4
88	Ø17 C Ring	3
89	1/4" x 8T Nyloc Nut	4
90	5/16" x 7T Nyloc Nut	2
91	M8 x 7T Nyloc Nut	1
92	M8 x 9T Nyloc Nut	1
93	3/8" x 7T Nyloc Nut	12
94	3/8" x UNF26 x 4T Lock Nut	2
95	3/8" x UNF26 x 11T Nut	2
96	3/8" x 7T Lock Nut	9
97	M8 x 6.3T Lock Nut	4
99	M8 x 170m/m J Bolt	1
100	Ø3/8" x Ø19 x 1.5T Flat Washer	21
101	Ø8.5 x Ø26 x 2.0T Flat Washer	4
102	Ø5/16" x Ø23 x 1.5T Flat Washer	4

103	Ø5/16" x Ø23 x 3T Flat Washer	8
104	Ø17 x Ø23.5 x 1.0T Flat Washer	1
106	Ø3/8" x 23 x 2.0T Curved Washer	18
107	Ø17 Wave Washer	4
108	Ø10 x 2T Spring Washer	6
109	M8 x 20m/m Carriage Bolt	1
110	7 x 14 x 0.8T E-Clip	4
111	5 x 16m/m Tapping Screw	1
112	M5 Speed Nut Clip	1
113	Beverage Holder	1
116	13/14m/m Wrench	1
117	12/14m/m Wrench	1
118	Phillips Head Screw Driver	1
119	L Allen Wrench	1
120	L Allen Wrench-M6	1
121	AC Electronic Module	1
122	100m/m Connecting Wire (White)	1
123	100m/m Connecting Wire (Black)	1
124	Power Cord(Connection socket)	1
125	TV Adapter	1
126	Power Cord	1
127	M4 x 12m/m Phillips Head Screw	2
128	M4 x 5T Nyloc Nut	2
129	80m/m Connecting Wire (White)	1
130	80m/m Connecting Wire (Black)	1
153	Pedal Foam (L)	1
154	Pedal Foam (R)	1
160	Foot Pad Adjusting Plate	1
200304		



800.258.4555
spiritservice@spiritfitness.com
www.spiritfitness.com



Spirit Fitness
3000 Nestle Road
Jonesboro, AR 72401



CS800 Owners Manual
© 2020 All Rights Reserved
Revision 2: 06.09.2020